

REVISION

REV	DATE	DESCRIPTION
A	2/10/20	INITIAL

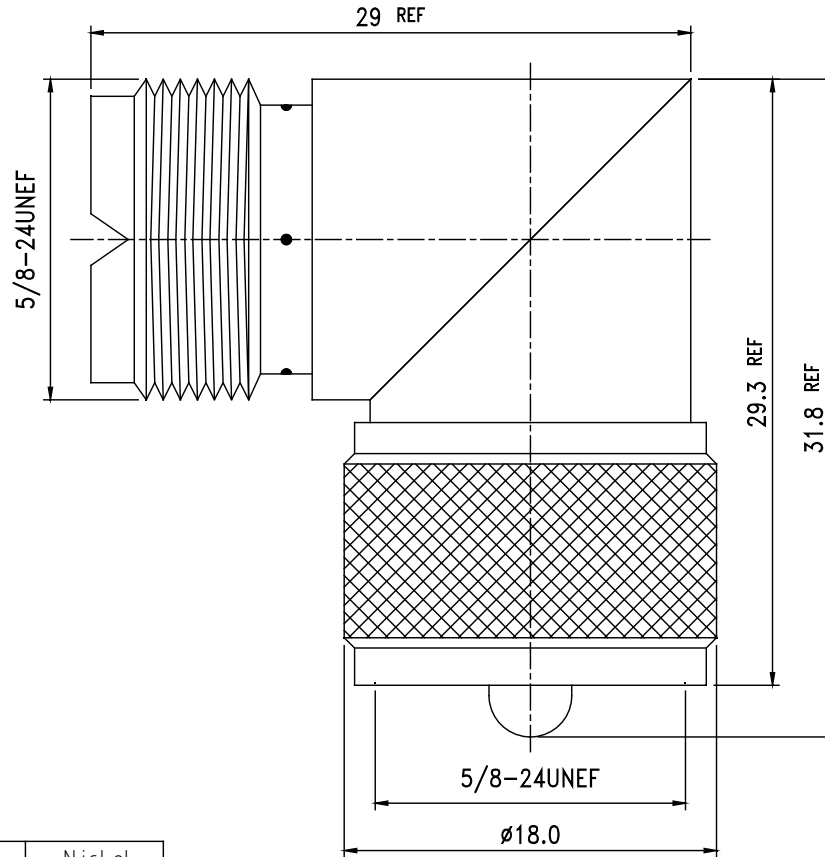

8.	Shell	Brass	1	Nickel
7.	Retaining Ring	Brass	1	None
6.	Insulation	Delrin	1	None
5.	Insulation	Delrin	1	None
4.	Pin	Brass	1	Gold
3.	Pin	Brass	1	Gold
2.	Body	Brass	1	Nickel
1.	Body	Brass	1	Nickel
NO.	DESCRIPTION	MATERIAL	Q'TY	FINISH

TOLERANCE	
.X	+/- 0.2
.XX	+/- 0.1
.XXX	+/- 0.05
ANGLE	+/- 0.5

UNITS	SIZE
mm	A
SCALE	NTS
SHEET 1 OF 1	

DRAWN BY:	CHECKED BY:	APPROVED BY:	CAD FILE
			17-15-DGN
PROPRIETARY AND CONFIDENTIAL THE INFORMATION IN THIS DRAWING IS THE SOLE PROPERTY OF TCC INDUSTRIES, INC. ANY REPRODUCTION IN PART OR AS A WHOLE WITHOUT THE WRITTEN PERMISSION OF TCC INDUSTRIES, INC. IS PROHIBITED.			

DESCRIPTION
UHF Adapter, Right Angle UHF Male to UHF Female



TCC INDUSTRIES INC.

7050 Village Drive unit E, Buena Park, CA 90621-2282
 Tel. 714.523.8885 - FAX. 714.562.0888
 E-Mail: info@tccinc.com Website: www.tccinc.com